

Dovre 250
Free Standing Stove
- including Smoke Control Version

**Instructions for Use,
Installation and Servicing**

For use in GB & IE (Great Britain and Republic of Ireland).



This appliance has been certified for use in countries other than those stated. To install this appliance in these countries, it is essential to obtain the translated instructions and in some cases the appliance will require modification. Contact Stovax for further information.

IMPORTANT

This appliance will become hot whilst in operation, it is therefore recommended that a suitable guard should be used for the protection of young children, the elderly or infirm. Do not attempt to burn rubbish in this appliance.

**Please read these Instructions carefully before installation or use.
Keep them in a safe place for future reference and when servicing the fire.**

The commissioning sheet found on page 3 of these instructions should be completed by the Installer.

COVERING THE FOLLOWING MODELS:

Dovre 250 Smoke Control Version

APPLIANCE COMMISSIONING CHECKLIST	3	COMMISSIONING	22
USER INSTRUCTIONS	4	MAINTENANCE & SERVICING	23
General Points	4	Annual Service	23
Using the Appliance for the first time	5	Removal of Log Guard	24
Recommended Fuels	5	Removal of Fire Brick	24
Lighting the appliance	6	Removal of Baffle	24
Running the appliance	7	Removal of Riddling Mechanism	24
Burning Tips	8	Fitting a New Door Glass	24
Ash Removal	9	Fitting a New Door Seal	24
Over night burning	9		
Over-Firing	9		
Chimney Fire	9		
General Cleaning	10		
Cleaning Glass	10		
Chimney Sweeping	10		
Care of Stove	10		
Seasonal Use	11		
Troubleshooting Tips	11		
		BASIC SPARE PARTS LIST	25
		SERVICE RECORDS	26
		EC DECLARATION OF CONFORMITY	27
INSTALLATION INSTRUCTIONS	12		
Technical Specifications	12		
Standard Features	12		
Packing List	12		
Dimensions	13		
SITE REQUIREMENTS	14		
Flue & Chimney	14		
Flue exit positions	15		
Hearth Dimensions	15		
Walls Next to Hearth	16		
PRE-INSTALLATION	17		
Flue	17		
Additional Ventilation	17		
Ventilation	18		
INSTALLATION	19		
Legal Requirements	19		
Installing the Appliance	19		
Top Flue Installation	19		
Rear Flue Installation	20		
Removal of Log Guard	20		
Fitting & Removal of Fire Bricks	20		
Fitting & Removal of Baffles	20		
Fitting & Removal of Riddling Mechanism	20		



This appliance has been approved by HETAS Ltd.

APPLIANCE COMMISSIONING CHECKLIST

To assist us in any guarantee claim please complete the following information:-

Dealer appliance was purchased from

Name:

Address:

.....

Telephone number:

Essential Information - MUST be completed

Date installed:

Model Description:

Serial number:

Installation Engineer

Company name:

Address:

.....

Telephone number:

Commissioning Checks (to be completed and signed)

Is flue system correct for the appliance YES NO

Flue swept and soundness test complete YES NO

Smoke test completed on installed appliance YES NO

Spillage test completed YES NO

Use of appliance and operation of controls explained YES NO

Instruction book handed to customer YES NO

Signature:

Print name:

USER INSTRUCTIONS

1. GENERAL POINTS

- 1.1 **Before use of this appliance please read these instructions fully.**
- 1.2 **All local regulations, including those referring to national and European Standards need to be complied with when installing the appliance.**
- 1.3 Only use for domestic heating in accordance with these operating instructions.
- 1.4 You must burn only approved fuels. Do not use with liquid fuels or as an incinerator.
- 1.5 Appliance surfaces become very hot when in use. Use a suitable fireguard if young children, elderly or infirm persons are present. Stovax offer firescreens, sparkguards and hearthgate systems for protection*. Your dealer can advise you about these products.
- 1.6 Do not place photographs, TV's, paintings, porcelain or other combustible items on the wall or near the appliance. Exposure to hot temperatures will cause damage.
- 1.7 Extractor fans or cooker hoods must not be placed in the same room or space as this can cause appliance to emit fumes into the room.
- 1.8 Do not obstruct inside or outside ventilation required for the safe use of this appliance.
- 1.9 Do not make unauthorised changes to the appliance.
- 1.10 The chimney must be swept at least once a year. See Section 12
- 1.11 **Do not connect, or share, the same flue or chimney system with another appliance.**

SMOKE CONTROL VERSION

- 1.12 These instructions apply to Dovre 250 (Part No. 7119/7160/7127/7161) when fitted with a Smoke Control kit (Part No.DV250SCKIT).

NOTE: This appliance has been independently tested to PD6434 and approved by DEFRA as an exempted appliance allowing it to burn wood in Smoke Control areas when fitted with a Smoke Control kit (Part No.DV250SCKIT).
- 1.13 To meet the Smoke Control requirement this appliance must be operated correctly in order to minimise the amount of smoke produced.
- 1.14 Burn only dry wood or approved smokeless fuels.
- 1.15 These instructions must be left with the user and kept with the original instructions they superseded.

SERIAL NUMBER

- 1.16 This number is required when ordering spare parts or making warranty claims.

Found on the data plate on the back of the appliance.

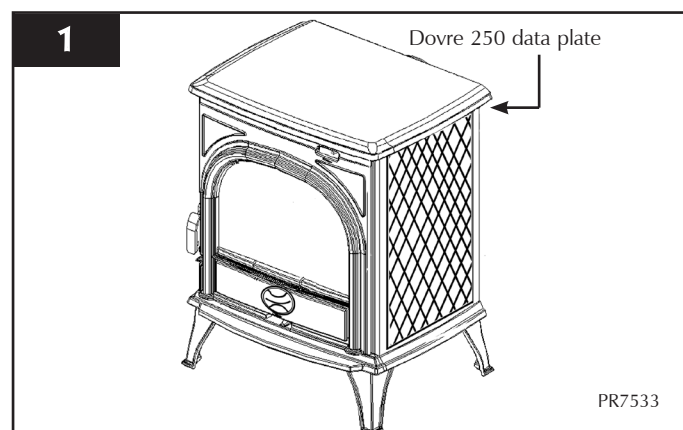

AIR CONTROLS

Double Air System

Several Dovre appliances have double air systems providing cleaner burning, and greater efficiency and control, See Diagram 2

- 1) Air wash - air drawn over the window cleans the glass. The source of Primary Combustion air when burning wood.
- 2) Primary Air - for use with solid fuel and initially with wood fires.

For Air Controls, See Diagrams over page

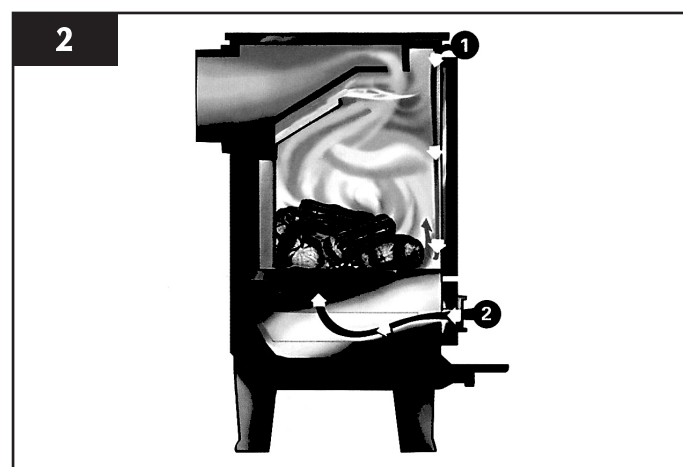

*In the U.K: These products must conform to BS 6539, Fireguards for use with solid fuel appliances. If appliance is operating unattended they must conform to BS 3248

USER INSTRUCTIONS

AIR CONTROLS

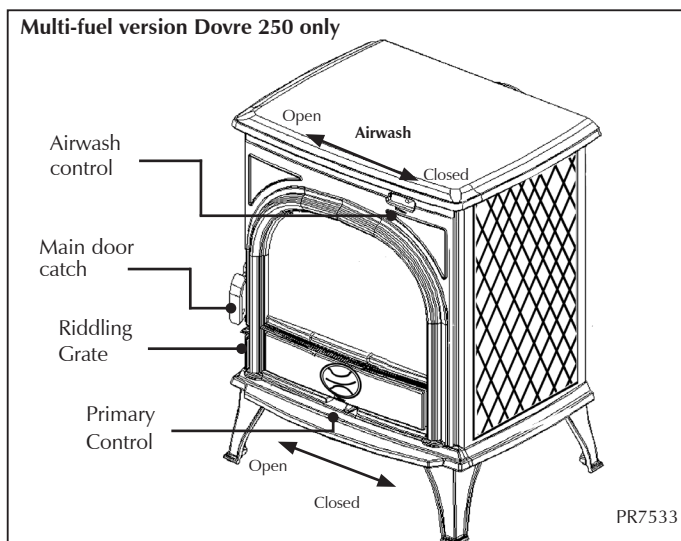

DOOR HANDLE

1.17 Use a protected gloved hand to operate.
See Diagram 3

DO NOT OPEN THE DOOR WITH BARE HANDS

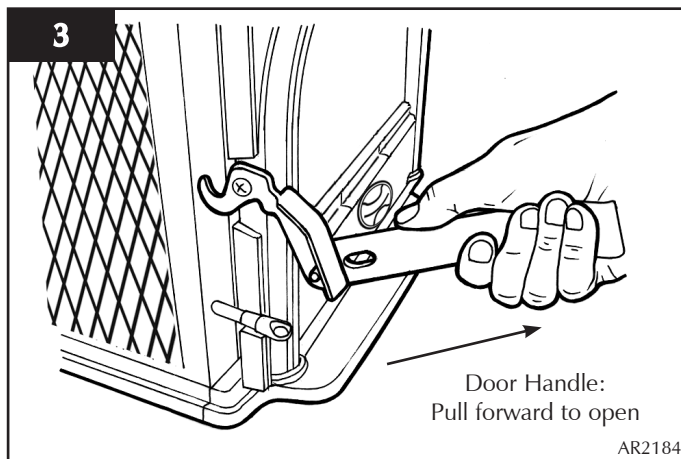

WARNING

Properly installed, operated and maintained this appliance will not emit fumes into the room.

Occasional fumes from de-ashing and refuelling may occur.

Persistent fume emission is potentially dangerous and must not be tolerated.

If fume emission does persist:

- Open doors and windows to ventilate the room
- Allow fire to burn out or safely dispose of fuel from the appliance

- Leave the room
- Check for chimney blockage and clean if required
- Do not attempt to relight until the cause of the emission has been identified and corrected. If necessary seek expert advice.

All open flued appliances can be affected by temporary atmospheric conditions which may allow fumes to enter the house. Because of this it is recommended that an electronic carbon monoxide detector conforming to BSEN50291 be fitted and maintained.

2. USING THE APPLIANCE FOR THE FIRST TIME

- 2.1 To allow the appliance to settle and fixing glues and paint to fully cure:
 - Operate the appliance at a low output for first few days
- 2.2 **Do not touch the paint during the first period of use.**
- 2.3 During this time the appliance may give off some unpleasant odours:
 - Keep the room well ventilated to avoid a build-up of fumes

3. RECOMMENDED FUELS

- 3.1 **Wood Logs:**
 - Burn only seasoned timber with a moisture content of less than 20%

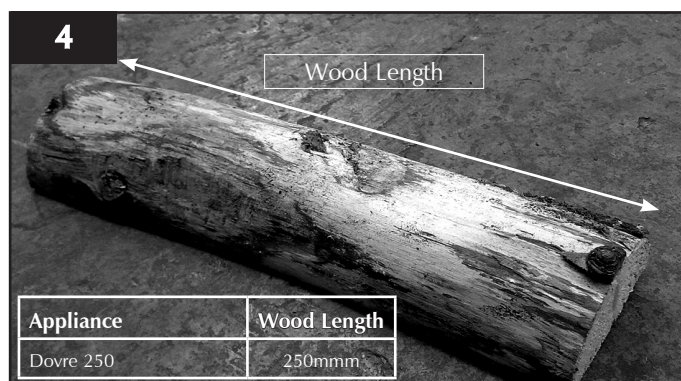

- Dry cut wood for 12 to 18 months before use
- Poor quality timber:
 - Causes low combustion efficiency
 - Produces harmful condensation
 - Reduces effectiveness of the airwash and life of the appliance

Do not burn construction timber, painted, impregnated / treated wood, manufactured board products or pallet wood.

USER INSTRUCTIONS

3.2 Fuel consumption.

As tested at nominal heat output to the requirements of EN 13240: 2001 for intermittent operation:

Description	Fuel Consumption
	Kg/hour Wood
Dovre 250	1.45

A number of factors can affect the performance of the appliance. See Section 8 for details.

4. LIGHTING THE APPLIANCE

4.1 For best results:

- Set air controls, See Diagram 5
(For individual model controls see diagrams on page 5)

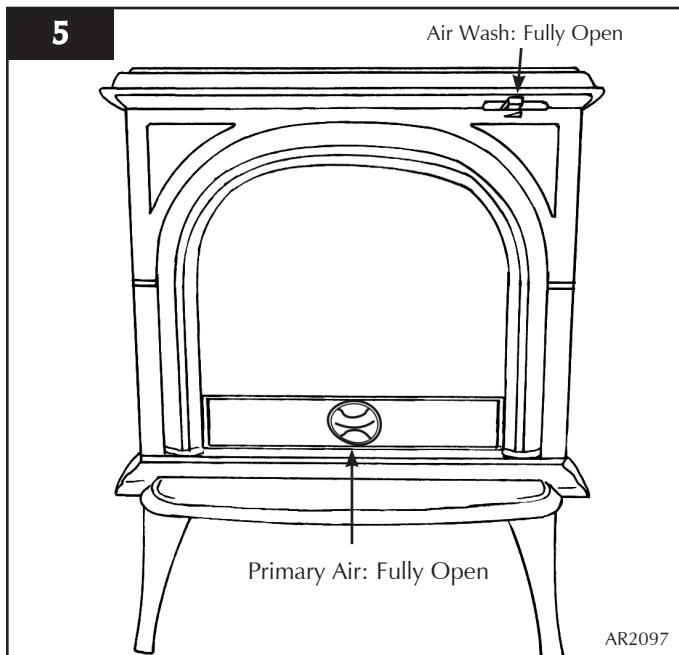

- Place firelighters or paper and dry kindling wood on the grate
- Light the paper or firelighters, See Diagram 6



- Leave the door slightly open as the fire establishes and the glass warms to avoid the build-up of condensation

- Add larger pieces of wood
Too many logs may smother the fire.

Do not load fuel above the log guard and the lower edge of baffle at the back of the firebox.

See Diagram 7

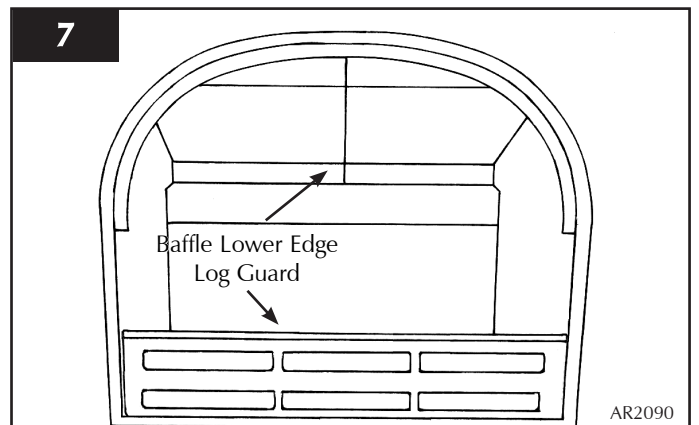

- Close the door

Do not leave the door open as this could over-fire and damage the appliance.

USER INSTRUCTIONS

5. RUNNING THE APPLIANCE

5.1 Burning Wood:

- Close the **Primary air control** (multi-fuel versions only) and use the **Airwash** to control the burn rate when appliance is at operating temperature, see Diagram 8

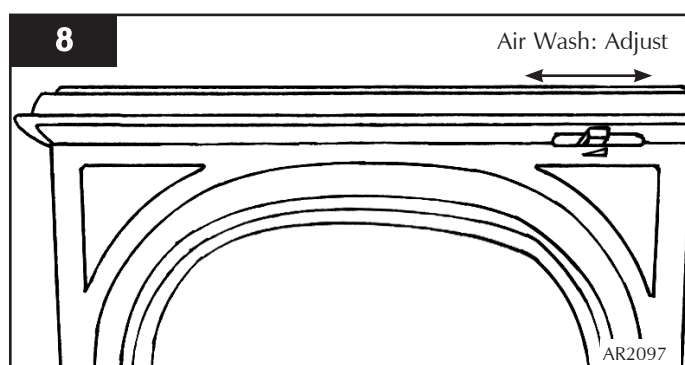

- Wood burns best on a bed of ash
 - Rake the embers evenly over the fire bed and open the **Airwash control** fully for a few minutes before re-fuelling
- 5.2 Burn new logs at high output for a few minutes before adjusting the **Airwash control**.
Refuel little and often for clean, efficient burning.
- Add a small amount of kindling and open the air controls if the firebed is low when the appliance is refuelled. This helps re-establish the fire. Do not close the air controls until the fire is burning well.
- 5.3 When burning wood at low output:
- Open the Primary Air and Airwash Controls fully for 3 minutes after refuelling
This ensures the fire is burning well before.
 - Fully close the Primary Air and adjust the Airwash to the low setting
- 5.4 Experience establishes settings to suit personal preferences.
- 5.5 Do not burn large amounts of fuel with the **Airwash control** closed for long periods of time. This reduces the glass cleaning effect and causes tars and creosotes to build-up in the appliance and flue system.
- 5.6 When in use, burning the appliance at high output for a short period also reduces tars and creosote.

Do not load fuel above the log guard and the lower edge of baffle at the back of the firebox.

See Diagram 7

6. BURNING TIPS

6.1 Fuel Quality (Wood)

Use wood with a moisture content of less than 20%. Seasoned logs have the bark beginning to lift and peel away and cracks radiating from the centre. They feel lighter than fresh cut wood of a similar size and sound hollow when struck against each other. Logs should not feel damp or have moss and fungal growths.

Symptoms related to wet wood:

- Difficulty starting and keeping a fire burning well
- Smoke and small flames
- Dirty glass and/or firebricks
- Rapid creosote build-up in the chimney
- Low heat output
- Short burn times, excessive fuel consumption and blue/grey smoke from the chimney

- Burn at high output at high output for a short period each day to avoid large build-ups of tars and creosote within the appliance and the flue system

- Use Stovax Protector chimney cleaner to reduce this problem

- When burning wood at low output settings open both air controls fully for 3 minutes after refuelling to ensure the fire is burning well before closing the Primary Air control fully and the airwash to the low setting

6.2 Air inlets puffing smoke

Combustion gases build up in the firebox and ignite as small explosions, causing smoke to puff out of the air inlets and other openings. This occurs if the air controls are shut soon after adding new fuel to a very hot fire. Stop by opening the air controls to increase combustion air and burning rate.

6.3 Flue Draught

The chimney has two main functions:

- 1) To safely remove the smoke, gases and fumes from the house.
 - 2) To provide a sufficient amount of draught (suction) in the appliance ensuring the fire keeps burning.
- Draught is caused by the rising hot air in the chimney when the appliance is lit.

Symptoms of poor performance related to flue draught include:

- Excessive fuel consumption (high flue draught)
- Poor burning control, overheating (high flue draught)
- Wind noise from air controls (high flue draught)
- Difficulty getting a fire going and keeping it burning well (low flue draught)
- Low heat output (low flue draught)
- Smoke entering room when doors opened (low flue draught)

USER INSTRUCTIONS

The construction, position, size and height of the chimney all affect the performance of the flue draught.

Other factors effecting the flue draught include:

- Trees or other buildings nearby causing turbulence
- High and gusty winds
- Outside temperature
- Outside weather conditions
- Incorrect additional ventilation to building
- Blocked flue / chimney

For advice on the correction of persistent flue problems consult a qualified solid fuel heating engineer before continuing to use the appliance.

6.4 Weather conditions

The weather conditions outside the building can effect the burning performance of the appliance. These could include:

Weather Conditions	Problem	Effect
Windy days	Buildings/Obstacles cause turbulent air around chimney.	Smoky Appliance
Calm days	Oversized Chimney.	Smoky Appliance
Damp / Rainy days	Flue temperature not hot enough. Rain water inside chimney.	Lighting and burning problems

To reduce these problems:

- Use good quality kindling wood to start the fire
- Burn initially at a high temperature for a short period
- Fit a rain cowl to the chimney

Your installer should advise you on possible solutions.

If the appliance emits smoke into the room continuously:

- Close the air controls and allow the appliance to go out
- Ventilate the room to clear the fumes
- Leave the room

Do not re-light the appliance until the problem is solved.

7. ASH REMOVAL

7.1 All fuels:

- Open Doors, See Diagram 10

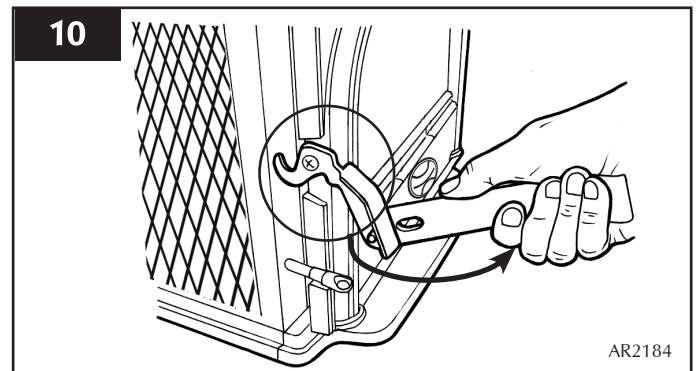

- Remove Ashpan, See Diagram 11

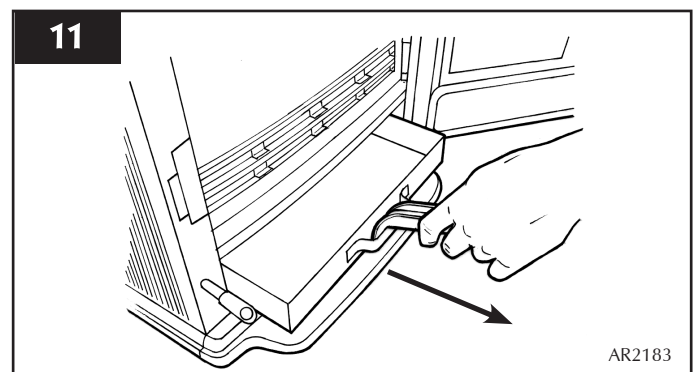

7.2 Multi-fuel:

- Riddle, See Diagram 12

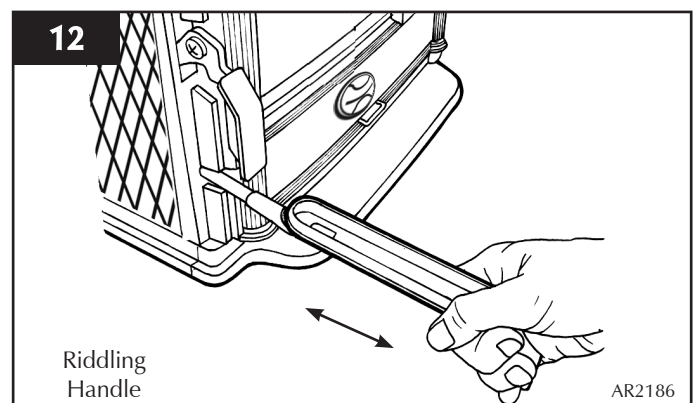

- Open Doors, See Diagram 10

- Remove Ashpan carefully. Heat can remain long after use, See Diagram 11

- Use gloves, or place the ash into a Ash Caddy (Part No. 4227)
- Remove ash at least once every week

USER INSTRUCTIONS

- Do not place hot ash in a bin made from plastic or any other combustible material.

8. EXTENDED BURNING

- 8.1 It is possible to get the appliance to burn for longer periods. In order to do this:
- De-ash prior to final refuelling
 - Set air controls to low combustion settings
This will blacken the glass over night but it will clear when operated at high output for a short period.
 - Use smokeless fuel or small, thick logs depending on fuel desired
- 8.2 **It is not recommended to extend the burning period in Smoke Control areas.** This process increases the amount of smoke produced.

9. OVER-FIRING

- 9.1 Do not over-fill with fuel or use at maximum output for long periods or over-firing can occur. If the flue pipe, flue collar or top plate glow red the appliance is over-firing:
- Close the air controls to reduce the output
- 9.2 Over-firing can cause permanent damage to the appliance.

10. CHIMNEY FIRE

- 10.1 If a chimney fire occurs:
- Shut all air controls immediately
 - Evacuate the building
 - Call the fire brigade
 - Do not re-enter the building until it is confirmed safe
- 10.2 **Do not use the appliance after a chimney fire until:**
- It has been inspected by a registered installer, confirming the appliance is safe to use***
 - The chimney system inspected and swept by a chimney sweep, confirming the system is structurally sound and free from obstruction before re-use.**
 - It is repaired as required before re-use.** Use only genuine Dovre replacement parts to keep your appliance in safe and efficient working order.

In the U.K:

* registered with HETAS (GB only)/INFO (Republic of Ireland only)

**This should be done by a NACS registered (UK only)/INFO registered (Eire only) chimney sweep, who will issue you with a certificate.

11. GENERAL CLEANING

- 11.1 **Allow appliance to cool thoroughly to avoid risk of burns:**
- Clean regularly, according to the level of use
 - Give attention to the baffle system, flue ways and removing ash
- Regular cleaning and maintenance will help give many years of safe use.
- Clean matt black appliances using Stovax Collodial black or Stovax Grate Polish
- To refresh painted finishes use Stovax Thermolac paint.
- Clean enamel finishes using warm soapy water and a soft clean cloth
 - Do not use aerosol sprays near an operating appliance

Wipe dry with a soft clean cloth before re-lighting. Do not leave unit without drying, as this may cause rust.

Do not use abrasive cleaner or cleaning pads to clean enamel finishes.

12. CLEANING GLASS

- Keep the glass clean with correct use of the Airwash system and good quality fuel
- Sometimes additional cleaning may be required.
- 12.1 This can be done as follows:
- Allow appliance to cool fully
- Do not clean hot glass.
- Use a soft cloth and Stovax Glass Cleaner
- 12.2 Before re-lighting the appliance:
- Dry the glass fully
- 12.3 **Do not use abrasive cleaner or cleaning pads.**

13. CHIMNEY SWEEPING

- 13.1 To maintain safe and efficient use of the appliance the chimney/flue must be inspected and swept at least once a year by a qualified chimney sweep.**

If the appliance is used continuously throughout the year or it is used to burn wood or smokeless fuel, more frequent sweeping is recommended.

The best time to have the chimney swept is at the start of the heating season.

The above applies even if burning smokeless fuels.

USER INSTRUCTIONS

- 13.2 The chimney, any connecting flue pipe and the appliance flue ways if incorporated, must be regularly cleaned.
- 13.3 Ensure adequate access to cleaning doors where it is not possible to sweep through the chimney.
- 13.4 If the appliance is believed to have previously served an open fire the chimney must be swept a second time within a month of regular use after installation.

14. CARE OF STOVE

Stovax has a range of cleaning and maintenance products and accessories to keep your appliance in good working condition. Your retailer can provide full details but here is a brief list of useful items:

Product Code	Description
3047	Extra long matches
5039	Gas lighter
4052	Log basket
3048	Wood sling - for easy carrying of logs
3016	Log tongs
4027	Extra long protective gloves
5038	Hearthgate - 5 section (for areas 1780x610mm)
5044	Hearthgate - 7 section (for areas 1780x405mm)
4227	Ash caddy - 382x102x306mm
4228	Ash caddy - 446x102x306mm
4229	Ash caddy - 382x102x459mm
4230	Ash caddy - 637x127x408mm
4231	Ash caddy - 306x178x459mm
2091	Ashclean vacuum cleaner attachment
4232	Steel brush

Your retailer can provide genuine spare parts such as replacement glass, door sealing rope and fire bricks when required. An annual service by a competent engineer is recommended to keep your appliance in best possible condition.



15. SEASONAL USE

- 15.1 Clean and service the appliance if it is not used during the warmer periods of the year as detailed in the *Maintenance and Servicing* section
- 15.2 Set the air controls 50% open to keep the appliance ventilated and stop the build-up of any moisture inside.
- 15.3 Before re-lighting the appliance:
- Remove the baffles
 - Clear any debris that may have accumulated
 - Check the flue is clear of any blockages

16. TROUBLESHOOTING TIPS

16.1 Stove glass blackening:

This has four possible causes:

1. **Incorrect use of airwash** – See Sections 1, 4 and 5 for the correct use of the air controls.
2. **Burning unseasoned wood** – See Section 3 to identify when wood is ready for burning.
3. **Stove operated at too low a temperature** - good working temperature is 300-500° F (120 – 250° C). A stove pipe thermometer can identify this problem (Part no 3046)
 - Burn with the airwash control fully open for approximately 20 minutes to cure this
 - The problem may be caused by damping your appliance down overnight.
4. **Problems with the flue** – in particular insufficient air pull. If the flue is not working efficiently the glass can blacken. A flue which has too much downdraft may be too short or needs lining or has too many bends. This can also cause blackening of your stove glass. Contact the installer or a flue specialist for advice.

16.2 Riddling mechanism jamming:

This occurs when fine ash builds up under the riddling bars preventing movement. To prevent this:

- Follow a regular cleaning routine for the inside of your appliance
- Lift out the riddling mechanism and remove all ash
- Replace riddling mechanism when cleaning is complete

16.3 Glass cracking:

Do not over tighten the screws on the glass clips when replacing the glass as this causes stress and the intense temperature changes can cause the glass to crack. For replacement glass contact your local dealer.

In the U.K:

* registered with HETAS (GB only)/INFO (Republic of Ireland only)
 **This should be done by a NACS registered (UK only)/INFO registered (Eire only) chimney sweep, who will issue you with a certificate.

USER INSTRUCTIONS

16.4 Appliance is producing tar:

This is identified by:

- A very strong pungent smell shortly after the appliance is lit and heats up
- Glass blackening
- Thick, brown and sticky tar oozes from the pipe joints

This is caused by burning damp wood and burning your appliance at too low a temperature;

- Use well seasoned wood and operate the appliance in the ideal temperature range

Tar is a major cause of chimney fires - if you experience problems with tar build up consult a chimney sweep before continued use of your appliance.

Ideal working temperature range is 130°C and 240°C (270°F – 465°F). Failing to close down the primary air control once the appliance has heated up to this range may cause the appliance to over-fire and to exceed the ideal temperature range. Over-firing can cause permanent damage to the appliance and invalidates your warranty.

TECHNICAL SPECIFICATION

DOVRE 250

MODEL: Dovre 250 Dovre 250 Smoke Control Version - fitted with Smoke Control Air Slider (Part No. DV250SCKIT)			Dovre 250
Nominal Heat Output	Wood	kW	4.9
	Solid Fuel	kW	4.9
Flue Draught at Nominal Heat Output	All	mm Wg	1.25
		inch Wg	0.05
Flue Gas Mass Flow	Wood	g/s	5.2
	Solid Fuel	g/s	5.1
Flue Gas Temperature at Spigot / Socket	Wood	°C	310
	Solid Fuel	°C	310
Flue Outlet Six (Top/Rear Option)		mm	125
		inch	5
Weight		Kg	80
Recommended Fuels	Wood	Seasoned wood (less than 20% moisture content)	
As tested to the requirements of EN 13240 for intermittent operation			

1. STANDARD FEATURES

- Primary air (under grate air for full multi-fuel use)
- Airwash (for wood burning / clean glass)
- Preset secondary air control (to ensure complete burning of flue gases)
- Riddling grate system for clean de-ashing
- Top or rear flue exit option

2. PACKING LIST

- Instructions
- Guarantee card
- Door handle tool
- Flue collar
- 4 X legs
- Fire Cement
- Scraper

TECHNICAL SPECIFICATION

DOVRE 250 DIMENSIONS

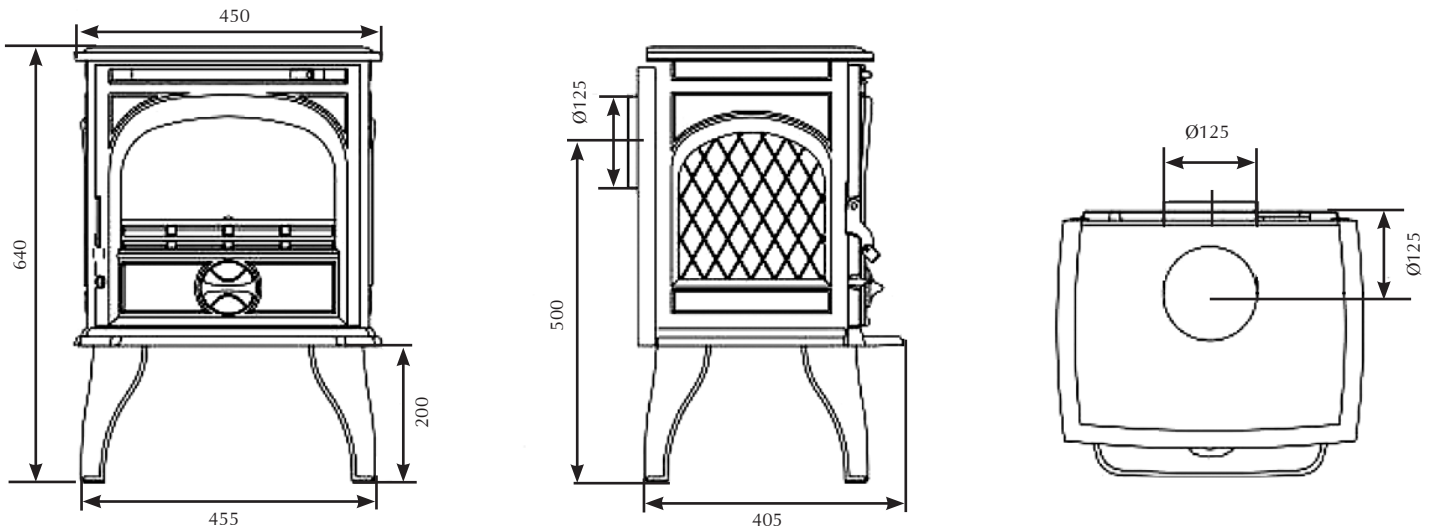

Description	Model	A	B	C	D	E	F (dia)	G	H
Dovre 250		590	452	357	130	445	125	145	45

All dimensions in mm. (25.4 mm = 1")

SITE REQUIREMENTS

1. FLUE OR CHIMNEY

- 1.1 The flue or chimney system must be in good condition. It must be inspected by a competent person and passed for use with the appliance before installation

Products of combustion entering the room can cause serious health risks.

- 1.2 You must check the following:

— The construction of the masonry chimneys, flue block chimneys and connecting flue pipe system must meet the requirements of the Building Regulations†

— A flexible flue liner system can be used if certified for use with solid fuel systems and installation complies with manufacturer's instructions and Building Regulations. The flue liner must be replaced when an appliance is replaced unless proven to be recently installed and in good condition.

— If it is necessary to fit a register plate it must conform to the Building Regulations†

— The minimum height of the flue or chimney must be 4.5m from the hearth to the top of the flue, with no horizontal sections, a maximum of 4 bends with angles of less than 45 degrees

— Ensure the connecting flue pipe it kept a suitable distance from any combustible material and does not form part of the supporting structure of the building

— Make provision to remove the appliance without the need to dismantle the chimney

— Any existing flue must be confirmed as suitable for the new intended use as defined in the Building Regulations

— The flue or chimney systems must be inspected and swept to confirm the system is structurally sound and free from obstructions**

— If the chimney is believe to have previously served an open fire the chimney must be swept a second time within a month of regular use after installation to clear any soots falls that may occurred due to difference in combustion levels.

— The flue exit from the building must comply with local building control rules.†

— Do not connect or share the flue or chimney system with another heating appliance

- 1.3 Do not connect to systems containing large voids or over 230mm square.

- 1.4 You must provide suitable access to enable the collection and removal of debris.

- 1.5 You must be able to sweep and inspect the flue when the appliance is installed.

- 1.6 You must check the flue draught with all windows and doors closed and any extraction fans in this or adjoining rooms running at maximum speed. (See next section for additional ventilation requirements)

Max. Draught = 2.0mm Wg

Min. Draught = 1.0mm Wg

In the U.K:

*BS 6461: Part 1, and the requirements of Building Regulations

**This should be done by a NACS registered (UK only)/ INFO registered (Eire only) chimney sweep, who will issue you with a certificate.

† Building Regulations Document J

Flue Plate:

Where a hearth, fireplace, flue or chimney is provided or extended (including cases where a flue is provided as part of refurbishment work), information essential to the correct appliance and use of these should be permanently posted in the building, to meet Requirement J4 of the Building Regulations (England and Wales), F3.12 (Scotland).

† Building Regulations Document J

Additional:

A new factory made system that complies to EN 1856; Part 1 can be used providing installation is to the requirements of:
i) BS 7566 Parts 1 -4
ii) the manufacturer's instructions
iii) Building Regulations.

For a guide containing information on Chimneys and Flues contact:

The British Flue & Chimney Manufacturers' Association,
FETA
2 Waltham Court
Milley Lane
Hare Hatch
Reading
Berkshire RG10 9TH

Tel: 0118 9403416

e-mail: info@feta.co.uk

SITE REQUIREMENTS

1. FLUE OUTLET POSITIONS

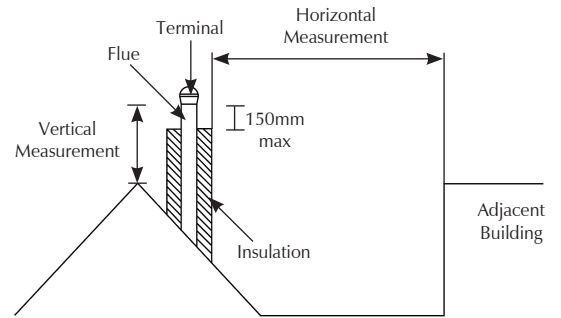
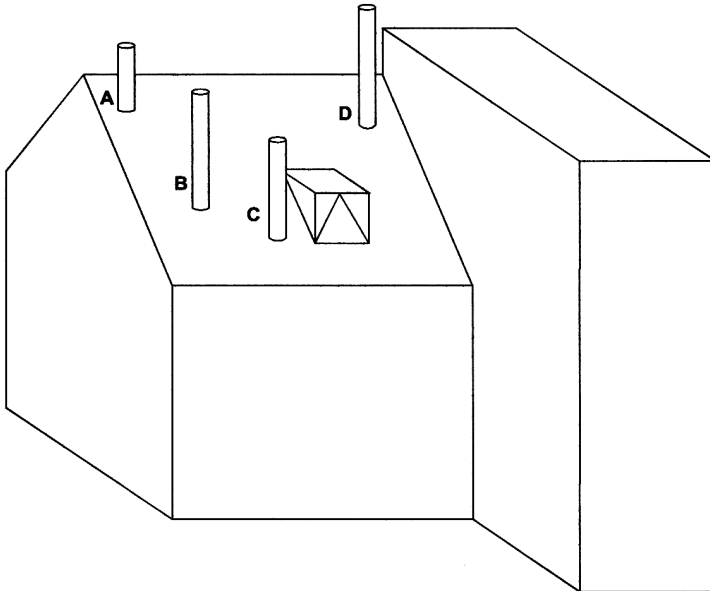

The vertical measurement is the lowest from either the point of discharge or 150mm above insulation.

IMPORTANT: Seek specialist advice if installing in a dwelling with a thatched roof

	Position On Roof	Minimum Clearances
A	On ridge or within 600mm	600mm above ridge
B	Elsewhere on roof	2300mm horizontally from roof surface and: a) 1000mm above highest point of flue exit from roof or b) as high as the ridge
C	On pitched, within 2300mm horizontally to openable window, dormer	1000mm above top of opening
D	Within 2300mm of another building	600mm above top of building

2. HEARTH DIMENSIONS

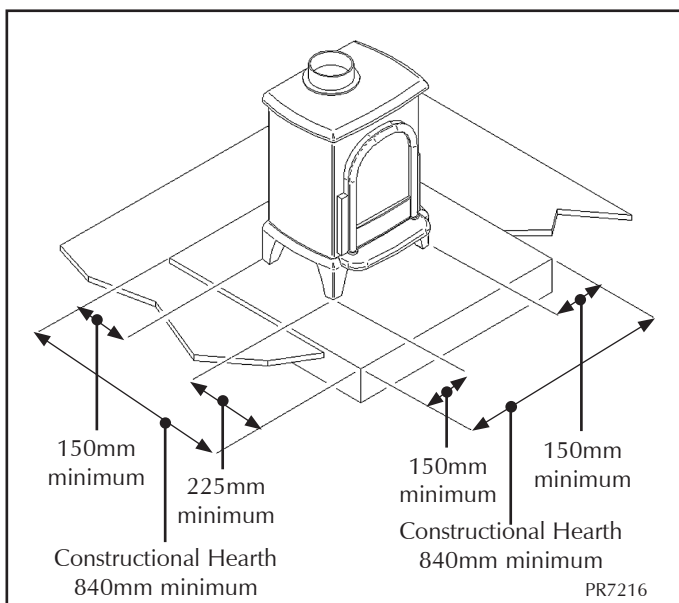

- 2.1 The appliance must stand on a non-combustible constructional hearth which is at least 125mm thick with the minimum dimensions as shown in diagram.
- 2.2 The building must have a suitable load-bearing capacity for the hearth and appliance.
 - Consult a structural engineer for advice before proceeding
- 2.3 When fitting into an existing hearth check:
 - That the appliance complies with current construction regulations and is at least the minimum sizes shown
- 2.4 If there is no existing fireplace or chimney it is possible to construct a suitable non-combustible housing and hearth setting. The flue must be installed in accordance with all local and national regulations and current rules in force .
 - Check if adding a new chimney to your property requires planning permission

SITE REQUIREMENTS

2. WALLS NEXT TO A HEARTH

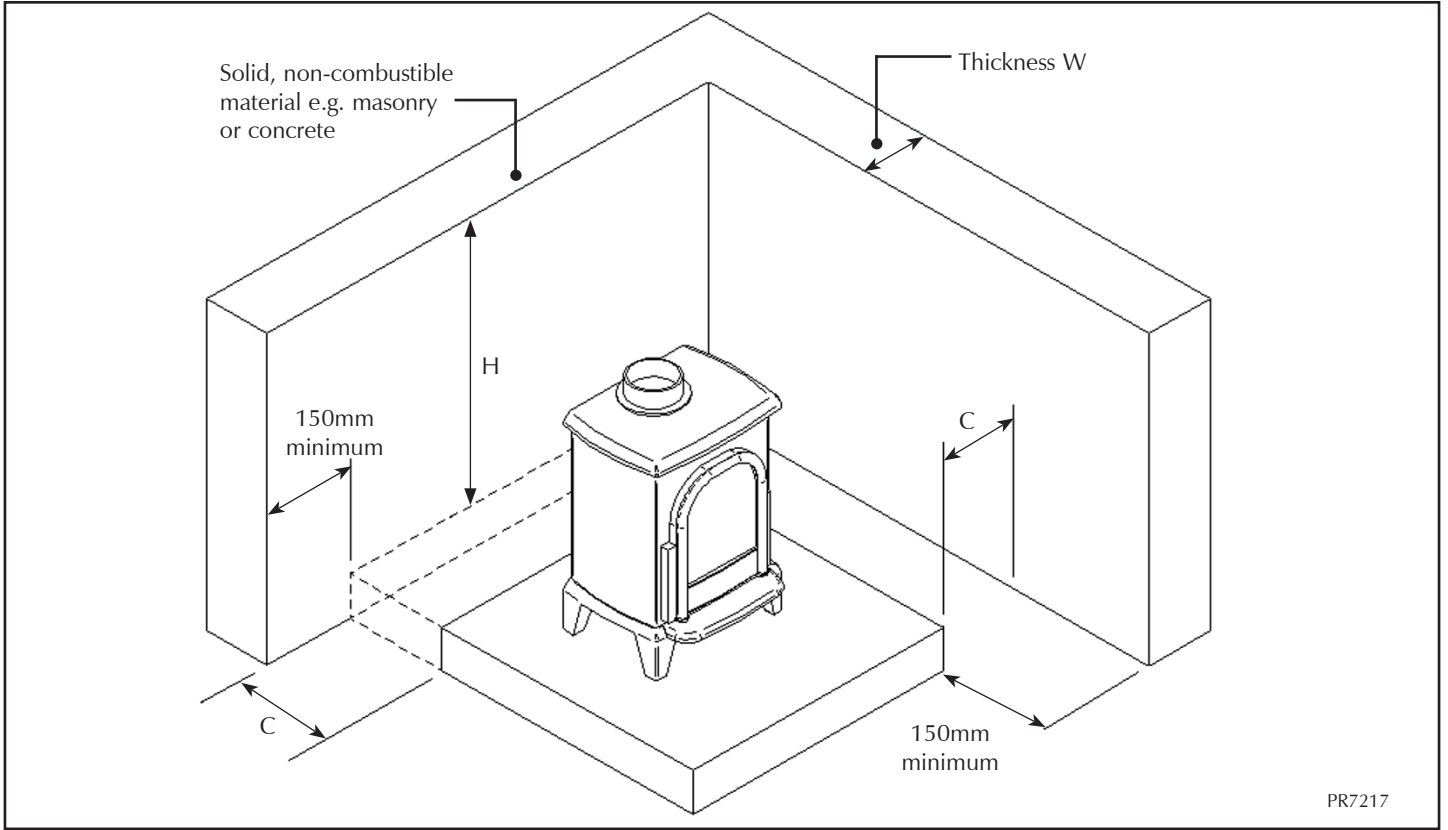

Position of Appliance & Hearth in relation to walls		Requirement for the walls	
Distance of hearth from wall 'C'	Distance of Appliance to wall	Min thickness of Wall 'W'	Min height of wall 'H'
0mm	0mm - 50mm	200mm	Height of appliance + 300mm Or 1200mm from the hearth (take largest dimension)
0mm	51mm - 300mm	75mm	
0 - 150mm	150mm +	75mm	1200mm
150mm +	300mm +	No Minimum Requirement	

Suitable clearance should be allowed around the stove to enable the correct fitting and maintenance of the appliance.

Any clearances should be confirmed by making a site survey and a physical check of wall thickness and dimensions.

PRE-INSTALLATION CHECKS

1. FLUE

MODEL: Dovre 250 Dovre 250 Smoke Control Version - fitted with Smoke Control Air Slider (Part No. DV250SCKIT)			Dovre 250
Flue/Chimney Size	Without flue liner Round (diameter)	mm	150
		inch	6
	Without flue liner system Square (diameter)	mm	135
		inch	5½
	With liner or Factory made system (diameter) <small>installed in accordance with manufacturer's instructions</small>	mm	†150
		inch	†6
Flue/Chimney <small>(*minimum height)</small>	All products	metre	4.5
		feet	15
* When measured from the top of the stove to the top of the flue, with no horizontal sections and a maximum of 4 bends with angles of less than 45°			

2. ADDITIONAL VENTILATION

2.1 Additional ventilation is required to comply with the requirements of the Building Regulations. This must be provided using a permanently open air vent, of the size listed, which is positioned so that it is not liable to be blocked both inside and outside the building.

2.2 Extractor fans or cooker hoods must not be placed in the same room or space as this can cause the appliance to emit fumes into the room.

2.3 **If any of these checks reveal problems do not proceed with the fitting of the appliance until they have been rectified.**

MODEL: Dovre 250 Dovre 250 Smoke Control Version - fitted with Smoke Control Air Slider (Part No. DV250SCKIT)			Dovre 250
Additional Ventilation	mm ²	0	
	cm ²	0	
	in ²	0	

PRE-INSTALLATION CHECKS

3. VENTILATION

- 3.1 This appliance requires ventilation to supply combustion air. Any room containing the appliance must have a permanent air vent opening with a total free area of at least 550mm^2 per kW of appliance rated output above 5kW.
- 3.2 Increase air supply provisions where a room contains multiple appliances.
- 3.3 If vents open into adjoining rooms or spaces there must be an air vent of at least the same size direct to the outside.
- 3.4 Permanent air vents should be non-adjustable and positioned where they are unlikely to become blocked.
- 3.5 Site the vents where cold draught is unlikely to cause discomfort. This can be avoided by placing vents near ceilings or close to the appliance, see Diagram opposite.

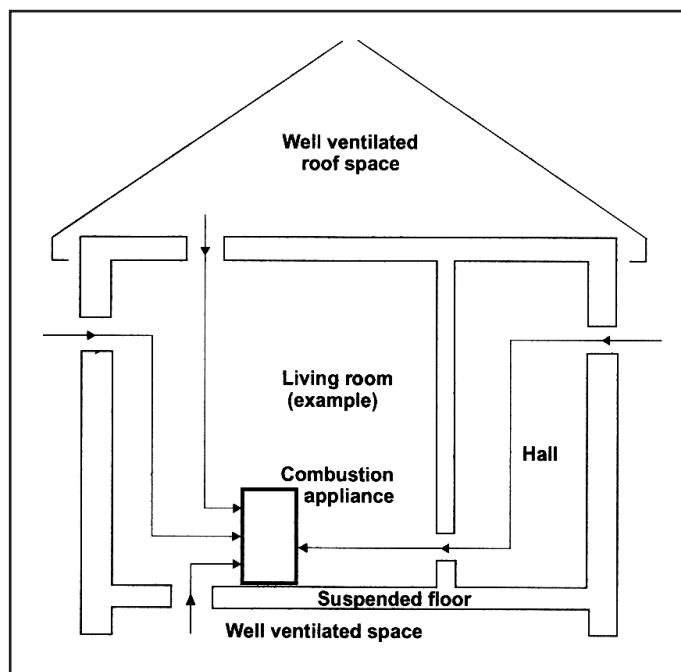

INSTALLATION INSTRUCTIONS

LEGAL REQUIREMENTS

Before installation of this product please read these instructions fully.

It is very important to understand the requirements of the national Building Regulations and standards*, along with any local regulations and working practices that may apply. Should any conflict occur between these instructions and these regulations then the regulations must apply.

Your local Building Control Office can advise regarding the requirements of the regulations.

The appliance must be fitted by a registered installer, or approved by your local building control officer.

Works must be carried out with care to meet the requirements of Health and Safety‡ and comply with the Health and Safety rules, and any new regulations introduced during the lifetime of these instructions.. Particular attention should be drawn to:

- **Handling:** The appliance is heavy. Adequate facilities must be available for loading, unloading and site handling.
- **Fire Cement:** Some fire cement is caustic and must not come into contact with the skin. Protective gloves must be worn. Wash hands thoroughly with plenty of water after contact with skin.
- **Asbestos:** This appliance contains no asbestos. If there is the possibility of disturbing any asbestos in the course of installation seek specialist guidance and use appropriate equipment.
- **Metal Parts:** Take care when installing or servicing the stove to avoid personal injury.

A faulty installation can cause danger to the inhabitants and structure of the building.

For users of this appliance:

Your building insurance company may require you to inform them that you have installed a new heating appliance. Check that your cover is still valid after installing the appliance.

If fitting this appliance in a Smoke Control Area a Smoke Control Air Slider (Part No. DV250SCKIT) must be fitted, See Section 6.

1. INSTALLING THE APPLIANCE

Each installation is unique to the property so it is not possible to give details to suit every setting. The installation must comply with Building Regulations and be made using "best practice" construction methods.

Many fireplace openings have a supporting lintel. Do not remove without supporting the remaining structure of the building. **Do not support the structure with the appliance or the flue system.**

- 1.1 **Take care when installing the appliance. Careless handling and use of tools can damage the finish and/or area.**

- Assemble the appliance by attaching the legs to the base of the appliance, Diagram 1

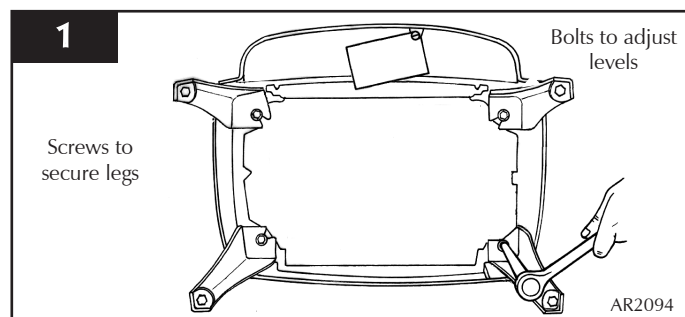

- Choose top or rear flue exit:

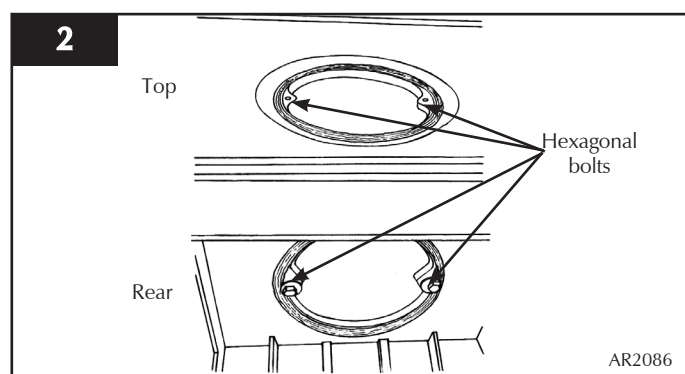

- Fit flue collar and blanking plate to suit
- Attach flue collar to top or rear with hexagonal bolts, see picture 2
- Seal with fire cement if desired
- Secure blanking plate with clamping bar, picture 3

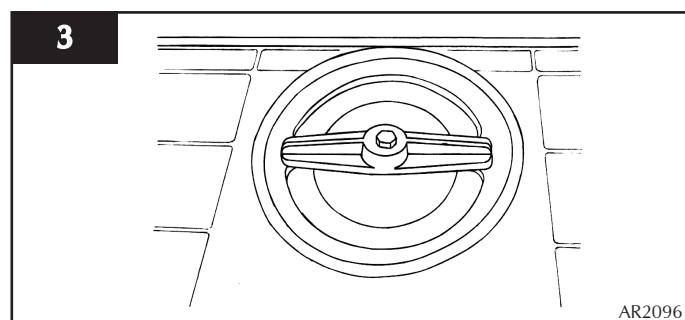

1.2 Top flue pipe installation

- Seal with fire cement if desired
 - Lift appliance into position
- Take care not to damage the hearth finish.
- Level using adjustable bolts, see picture 1
 - Connect appliance to the chimney using flue pipe
 - Secure with self tapping screw
 - Seal the connecting joints

In the U.K:

- * • England and Wales – Document J / Scotland - Part F, Building Regulations, 1997 Technical Guidance Document J Heat Producing Appliances (Republic of Ireland only)

‡• registered body: HETAS (GB only)/INFO (Eire)

INSTALLATION INSTRUCTIONS

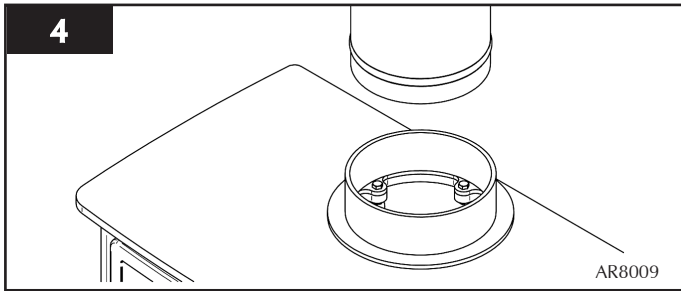

The Flue must be installed in accordance with manufacturers instructions.

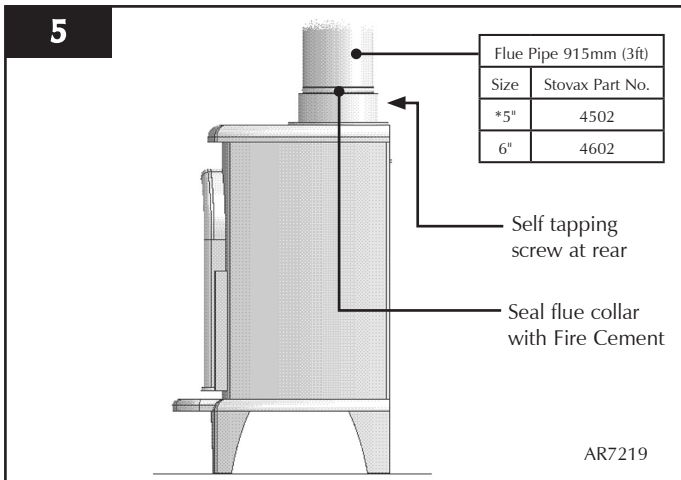

1.3 Rear flue pipe installation

- Insert a tee into the flue collar
The tee piece is used as cleaning access.
- Lift appliance into position
Take care not to damage the hearth finish.
- Level using adjustable bolts, see picture 1
- Connect tee to the chimney using flue pipe
- Secure with self tapping screw
- Seal the connecting joints

Do not use a 90° elbow to make this connection

The Flue must be installed in accordance with manufacturers instructions.

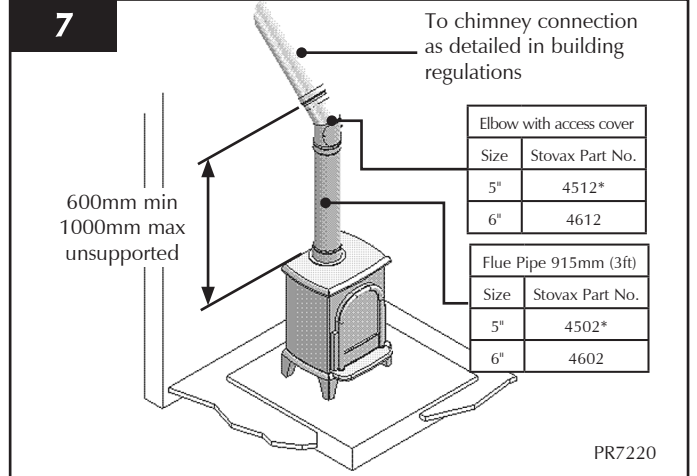
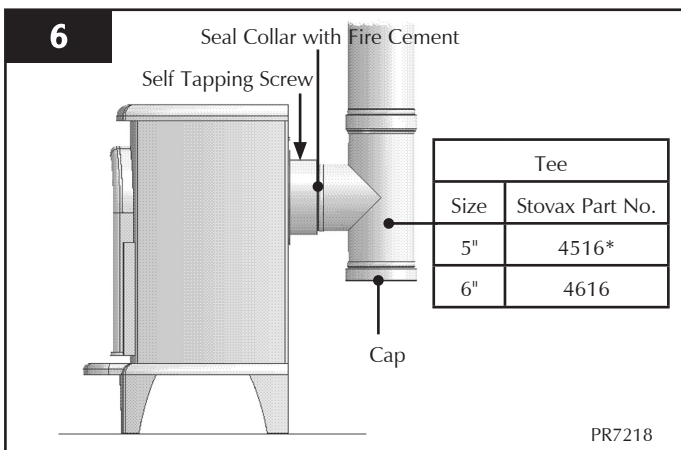

2. REMOVAL OF THE LOG GUARD

- 2.1 To remove the Log guard:
- Lift Log Guard clear of the supporting brackets
 - Rotate to clear the sides of the door opening.
- Do not use appliance without the log guard in position.**

3. FITTING AND REMOVAL OF THE FIREBRICKS

- 3.1 Remove the firebricks as part of the routine maintenance. This can be carried out without the use of tools.
- 3.2 Allow the appliance to cool fully before removing firebricks.
- 3.3 Take care when handling, as bricks can become fragile after use. Life span depends on the type of fuels burnt and the level of use.
- Replace damaged bricks as soon as possible
- 3.4 To remove bricks:
- Remove side bricks
 - Slide rear bricks forward to remove
 - Replace in reverse order

4. FITTING AND REMOVAL OF THE BAFFLES

- 4.1 The appliance is fitted with a baffle in the top of the firebox to maintain efficient combustion.
- Allow the appliance to cool fully before removing baffle system
 - Remove the Log Guard from the appliance to give access to the firebox
- 4.2 Take care when handling the bricks; they can become fragile in time. This is normal and wear depends on the type of fuels burnt and the level of use.

INSTALLATION INSTRUCTIONS

IMPORTANT

- Remove and clean the baffle system to ensure the flue ways are clear of soot and debris and to ensure the safe and efficient operation of the stove
- Frequency of cleaning depends on the operating conditions
- Replace any damaged baffles immediately
- **DO NOT MODIFY THE BAFFLE SYSTEM**
- Remove the baffle
- Lift the baffle plate
- Rotate it and slide it out through the front
- Replace in reverse order

5. FITTING AND REMOVAL OF THE RIDDLING MECHANISM

- 5.1 The riddling mechanism can be removed for cleaning to maintain good working condition.

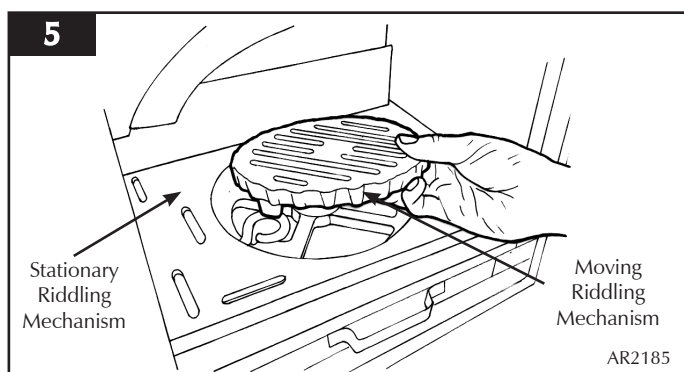

6. FITTING THE SMOKE CONTROL KIT

- 2.1 To install the Smoke Control kit:
- Smoke Control Air Slider (Part No. DV250SCKIT)
 - Remove all internal packaging and Log Guard, Diagram 1

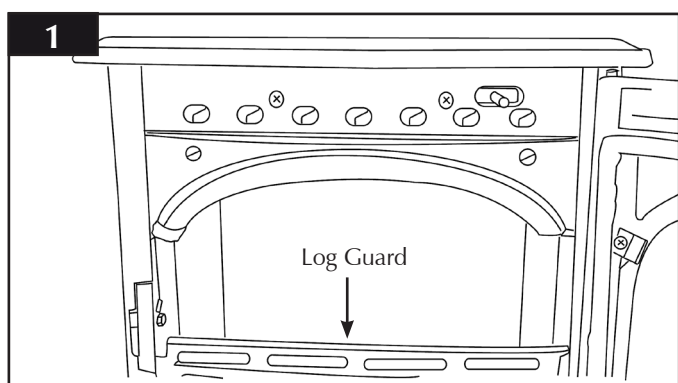

- To remove the Log Guard:
- Lift, rotate and Pull out through front of appliance, Diagram 2

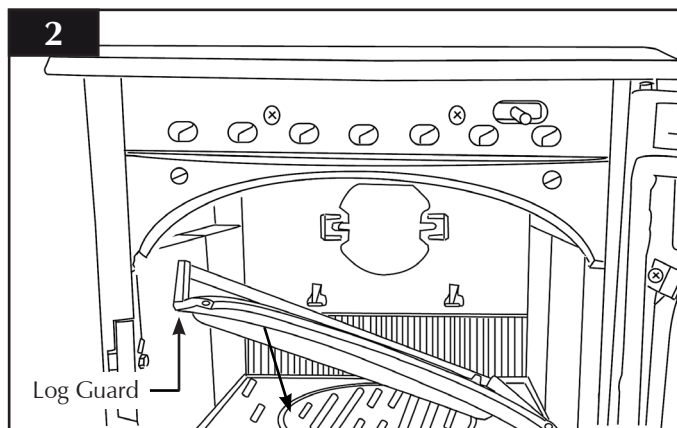

- 2.2 • Lift and slide the Baffle through the front of the appliance to remove
- 2.3 • Remove the two screws on the Airwash chamber and remove, see diagram 3
The nuts are located on the back of the Airwash chamber. Use a 10mm spanner to hold the nuts.

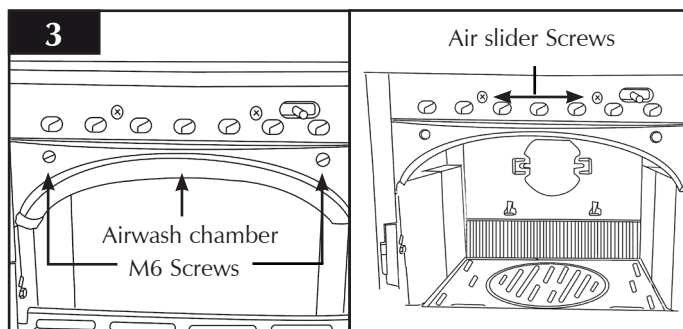

Note: If the kit is fitted before appliance installation the top plate can be removed for easy access.

- 2.4 • Remove the M6x2 screws on the Air slider, Diagram 3&4
The nuts are located on the back of the Air slider. Use a 10mm spanner to hold the nuts.

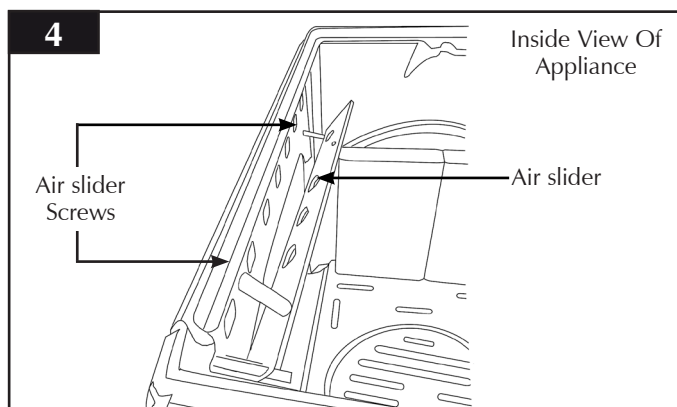

- 2.5 Replace Air slider with the Smoke Control version
- 2.6 Fitting is the reverse of the above
- 2.7 Ensure the Air slider screws are tightened to a tension that ensures movement when the Airwash is operated.

COMMISSIONING

COMMISSIONING

1.1 To commission:

- Replace the firebricks, baffle, and log retainer
- Check the door alignment and catch operation, adjust if required, see Installation Section 6. Adjusting Door hinges
- Check the soundness of door seals, castings and joints
- Check the operation of the air controls

1.2 Now carry out a final smoke draw test:

- First warm the flue with a blowlamp, or similar, for about 10 minutes
- Place a smoke pellet on the centre of the grate, with the air controls open
- Close the door
Smoke should now be drawn up the flue and be seen to exit from the flue terminal
- Complete test with all doors and windows closed in the room where the appliance is fitted
- If there are any extractor fans in adjacent rooms, the test must be repeated with the fans running on maximum and interconnecting doors open
- Check the effect of ceiling fans during the test

If the test fails, re-check the suitability of the flue system and ventilation. An inadequate air supply to the room is potentially dangerous.

- Light the appliance and slowly increase the temperature to operating levels
- Ensure no combustion products enter the room
- Open the main fire door when the appliance reaches operating condition and carry out a spillage test with a smoke match or pellet around the door opening

1.3 If excessive spillage occurs:

- Allow the appliance to cool and re-check the flue system and ventilation

1.4 Finally:

- **Explain the safe operation of the appliance and the use of the controls to the user and the importance of only using suitable fuels**
- **Explain the cleaning and routine maintenance requirements**

- **Explain the requirement to use a suitable fireguard when children, elderly or infirm persons are near the appliance**

- **Record dealer/supplier details and installer details in *Instructions***

- **Record serial number in page 3 of *Instructions***
This number is required when ordering spare parts and making warranty claims

- **Give the copy of the *Instructions* to the customer**

MAINTENANCE and SERVICING

For a complete list of spare parts and accessories contact your Stovax or call 01392 474011

1. ANNUAL SERVICE

1.1 At the end of the heating season strip, inspect and clean the appliance as detailed:

- Allow appliance to cool

- Remove all of the following internal parts; baffle, firebricks, complete grate, and ash pan. For Multi-fuel versions remove the complete grate and ash pan.

See sections 5 and 6 on how to remove the baffles and firebricks. Take care handling firebricks, as they can become fragile after a period of use.

- Vacuum clean any remaining ash and debris from the inside of the appliance.

Stovax offer a filter/collection attachment for your vacuum cleaner to protect it from fire ash. Ash Clean (Stovax Part No. 2091).

- Clean the internal surfaces of the appliance using a wire brush and scraper as required
Vacuum and brush the resulting debris from the appliance.

- Clean the grate parts with a wire brush, and check the parts for any damage

- Replace any damaged parts

- Check and clean the firebricks with a soft brush

- Replace broken bricks

Some surface damage will occur during use. The life of the bricks will depend on the type of fuels burnt and the level of use. Damaged bricks should be replaced as soon as possible.

- Re-fit cleaned internal parts

- Remove the glass from the door, See section 7 page 20, and discard all old rope seals

- Remove the door rope seal from the outer edge of the door and clean the old glue from the door sealing rope groove

- Clean the door glass using Stovax Glass cleaner and a soft cloth

Do not use abrasive cleaners to remove tar or soot deposits from the glass.

- Replace the glass edge seal with new and re-fit the glass into place in the door

- Fit new door rope seal, gluing it in place with Stovax Thermic Seal rope adhesive

- Press the new door sealing rope into the locating groove, placing the joint in the middle of the lower edge of the door.

When fitting new door seals, close the appliance door and leave for at least 12 hours before using. This allows the adhesive to fully bond to the seal before use.

- Lightly oil the door catch mechanism and hinge pins
Avoid getting oil onto the door seals and glass.

To refresh painted finishes use Stovax Thermolac paint.

1.2 Use genuine Stovax replacement parts to keep your appliance in safe and efficient working order. Your local Stovax dealer can provide you with the parts you require.

This is a list of the maintenance products you may need to use

Task	Product name	Code Number
Glass cleaning	Stove glass cleaner 500ml (wipe on)	4111
	Stove glass cleaner (spray on)	4103
Preventing build-up of creosote in flue	Protector (15 sachets)	7002
	Protector (1kg tub)	7025
Sealing flue pipe joints	Fire Cement (500g tub)	2020
	Fire Cement (600g cartridge)	2021
Re-painting	Thermolac Black (400ml aerosol)	2019
	Thermolac Black (200ml brush-on)	2057
Cleaning matt black Appliances	Colloidal black (85ml)	7000
Protecting your hands	Heat resistant leather gloves	4008
Door sealing rope	14mm Black rope seal (handy pack)	5000
	14mm Black rope seal (25m reel)	4670
Glass sealing tape	3mm Black rope seal (handy pack)	4975
	3mm Black rope seal (25m reel)	4974
Thermic seal glue	(50ml bottle)	5037
Soft rope	10mm diameter	4965
Ash Clean	Vacuum Cleaner Attachment	2091

These products, available from your local dealer, along with regular maintenance and use of correct fuels, will keep your appliance in the best possible condition.

1.3 If you require more information about Stovax group products visit our web site www.stovax.com

MAINTENANCE and SERVICING

- 1.4 Using the appliance for the first time:
- Burn at a low output for the first day of use
This allows the seals, fixing glues and paint to fully cure.
- 1.5 During this time the appliance may give off some unpleasant odours:
- Keep the room well ventilated to avoid a build-up of fumes.
- 1.6 Your dealer can carry out service and maintenance.

2. REMOVAL OF THE LOG GUARD

- 2.1 To remove the Log guard:
- Lift Log Guard clear of the supporting brackets
 - Rotate to clear the sides of the door opening.
Do not use appliance without the log guard in position.

3. FITTING AND REMOVAL OF THE FIREBRICKS

- 3.1 See *Section 3 Fitting & Removal of Firebricks* in *Installation section*.

4. FITTING AND REMOVAL OF BAFFLE (2 PARTS)

- 4.1 See *Section 4 Fitting & Removal of Baffle* in *Installation section*.

5. REMOVAL OF RIDDLING MECHANISM

- 5.1 See *Section 7, Installation Instructions*, to remove and replace the riddling mechanism.

6. FITTING A NEW DOOR GLASS ALL MODELS

- 6.1 To maintain the safe use of your appliance you may need to replace a damaged door glass. To complete this operation:
- Remove the door, by opening, removing the hinge pins and lifting the door free of the hinge blocks
 - Lay the door face down on a soft flat surface, to protect the paintwork and glass
 - Remove the glass clip fixing screws The old glass can then be lifted clear of the door. (Note how the 3mm sealing rope is placed between the glass and the door.) Dispose of the old glass safely.
 - Clean and re-paint the rear of the door if required
Clean the screws with light oil and coat with high temperature anti-seize grease, this will aid future removal.

- Fit a new sealing rope between the new glass and the door, and place the glass into position in the door

- Place the glass fixing clips in to position and re-fix with the clean fixing screws, tighten the screws evenly until the clips hold the glass
Do not over tighten the clips as this could break the glass.

- 6.2 Fit only original Dovre ceramic glass, which is suitable to use in high temperature applications.

- 6.3 Using the appliance with a damaged door glass could cause dangerous fumes to enter the room, or the appliance to over fire, resulting in damage.

7. FITTING A NEW DOOR SEAL ALL MODELS

- 7.1 To maintain the safe use of your appliance you need to replace damaged or worn door sealing rope. To complete this operation:

- Remove the door from the appliance, by opening, removing the hinge pins and lifting the door free of the hinge blocks

- Lay the door face down on a soft flat surface, to protect the paintwork and glass

- Remove the old rope and scrape old glue from the locating groove
Clean the locating groove with a clean dry cloth to remove all old dust and debris.

- Squeeze a generous bead of fresh Stovax Thermic Seal glue into the rope locating groove

- Press the new Stovax rope into the locating groove, placing the joint in the middle of the lower edge of the door

- Refit the door and close the door to apply pressure to the new rope

- Leave the appliance closed for at least 12 hours before lighting the appliance and using at a low output for approximately one day

- 7.2 Using the appliance with a damaged door seal can cause dangerous fumes to enter the room, or the appliance to over fire, resulting in damage.

BASIC SPARE PARTS LIST

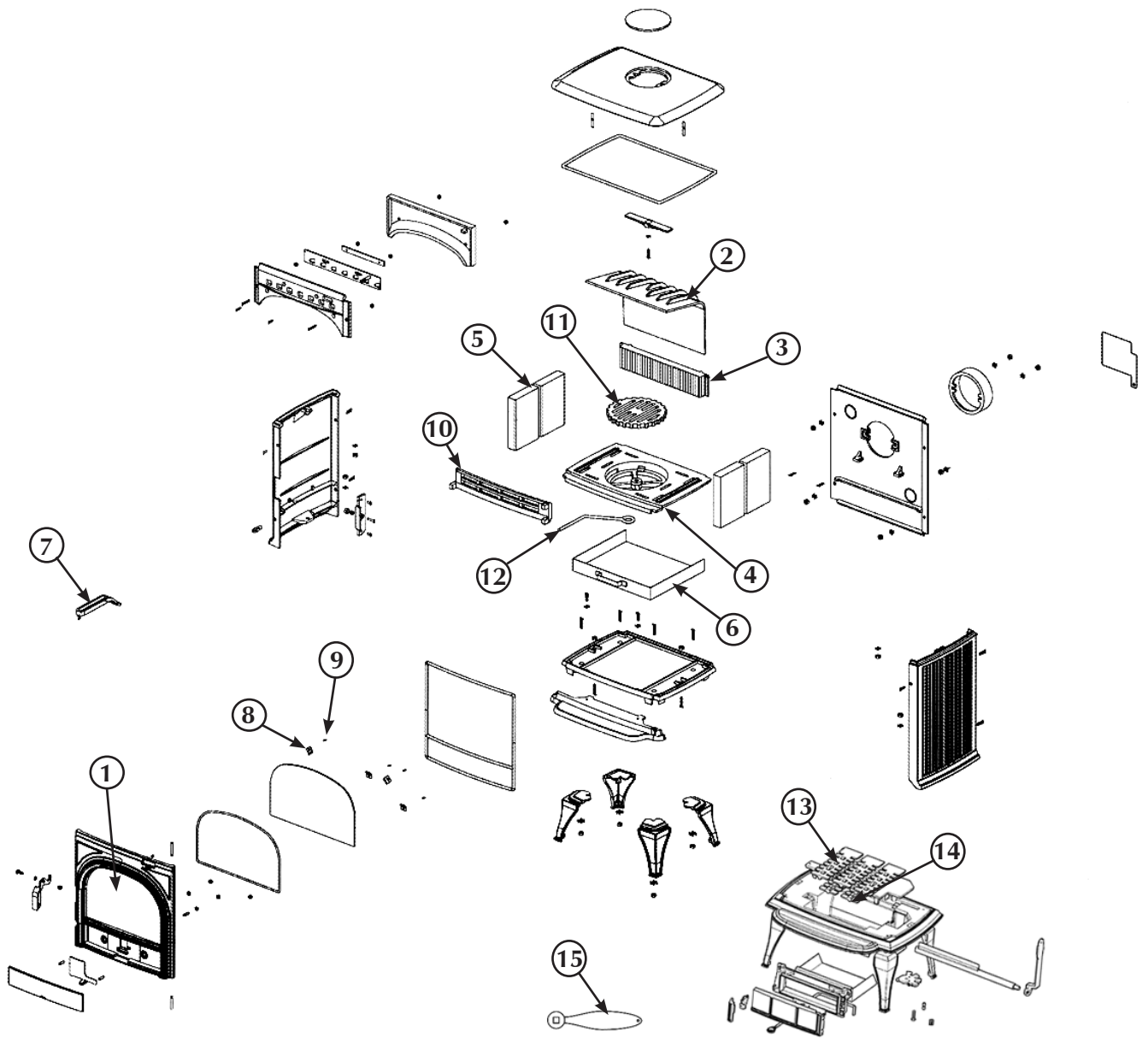

DOVRE 250

Diagram No.	Description	Part No.
1	Door Glass	GL0260
2	Baffle	DV-76140
3	Inner back plate	DV-08331
4	Grate Holder	DV-61111
5	Side Fire brick	DV-77333.0
6	Ashpan	DV-05220
7	Ashpan handle	DV-SLT5
8	Glass Retainer	DV-W/015/E
9	Glass Retainer Screw	DV-W/018/E
10	Log Retainer	DV-Z/2517/G
11	Centre Grate	DV-61111
12	Riddling Rod	DV-61309.0

SERVICE RECORDS

1ST SERVICE

Date of Service:.....

Next Service Due:.....

Signed:.....

Dealer's Stamp/HETAS Registration Number

2ND SERVICE

Date of Service:.....

Next Service Due:.....

Signed:.....

Dealer's Stamp/HETAS Registration Number

3RD SERVICE

Date of Service:.....

Next Service Due:.....

Signed:.....

Dealer's Stamp/HETAS Registration Number

4TH SERVICE

Date of Service:.....

Next Service Due:.....

Signed:.....

Dealer's Stamp/HETAS Registration Number

5TH SERVICE

Date of Service:.....

Next Service Due:.....

Signed:.....

Dealer's Stamp/HETAS Registration Number

6TH SERVICE

Date of Service:.....

Next Service Due:.....

Signed:.....

Dealer's Stamp/HETAS Registration Number

7TH SERVICE

Date of Service:.....

Next Service Due:.....

Signed:.....

Dealer's Stamp/HETAS Registration Number

8TH SERVICE

Date of Service:.....

Next Due:.....

Signed:.....

Dealer's Stamp/HETAS Registration Number

9TH SERVICE

Date of Service:.....

Next Due:.....

Signed:.....

Dealer's Stamp/HETAS Registration Number

10TH SERVICE

Date of Service:.....

Next Service Due:.....

Signed:.....

Dealer's Stamp/HETAS Registration Number

CE-conformiteitsverklaring
Declaration de conformité CE
EC Declaration of conformity
Konformitätserklärung CE



Notified body: 1641

Wij,
Nous,
We,
Wir,

Dovre nv, Nijverheidsstraat 18, B2381 Weelde,

verklaren bij deze dat de kachel 250 conform is volgens de EN 13240.
déclarons que le poêle 250 est conforme au norme EN 13240.
declare that the stove 250 est in conformity with the EN 13240.
Erklären daß das Produkt 250 entspricht EN 13240.

Weelde, .09.01.2006

T. Gechem

A handwritten signature in black ink, appearing to read 'T. Gechem', is written over a vertical line. The signature is stylized and cursive.



United Kingdom and Eire distributors for Dovre:

STOVAX

Stovax Limited, Falcon Road, Sowton Industrial Estate, Exeter, Devon, England, EX2 7LF.

Telephone: **(01392) 474011** Fax: **(01392) 219932**

E-mail: dovre@stovax.com Internet: www.dovre.co.uk